



Grand Manufacturing LLC
www.grandmfgllc.com

Project Name: _____

SIA #

Location: _____

Item #: _____ Qty: _____

AIA #

Model #: _____

Model:
GUR-28-D2

Grand Undercounter Series

28" 2 door undercounter refrigerator - Drawer



Features & Benefits

System

- Digital temperature control & monitor
- Hot gas condensate system
- Automatic evaporation & defrost system

Strong & Durable Cabinet Finish

- Stainless steel finished top, front, sides and doors
- Galvanized steel finished back and bottom

Components

- Accommodates 6" deep pans (pans are optional)
- 5" Heavy-duty casters with brakes standard

Heavy Duty Drawer

- Stainless steel made telescoping drawer slide with roller bearing wheels
- Stainless steel made drawers hold up to 88 pounds (40kg)

Temperature

- Enhanced Airflow Holds Product Temperature 32°F~41°F (0°C~5°C)

Options

- Drawer Mixed Model Available
- Free Hcfc & Hfc Refrigerant Model (R-290)

Drawers	Shelves	HP	AMPS	Cabinet Dimensions (inches)			Crated Weight (lbs.)
				W	D	H*	
2	0	1/5	3.2	27 1/2	30	35 7/8	174

* Exterior height include 5" for castor height.

GRAND has the right to change specifications without further notice.



Approvals:

Available At:

Model:
GUR28-D2

Grand Undercounter Series

28" 2 door undercounter refrigerator - Drawer

Plan View

Top View

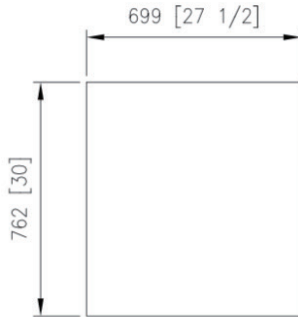

Front View

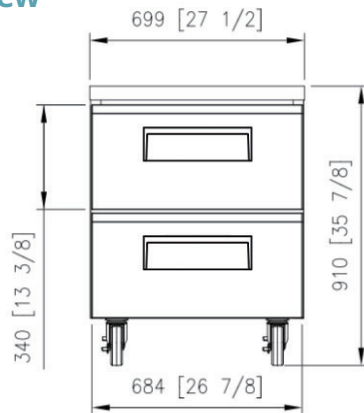

Side View

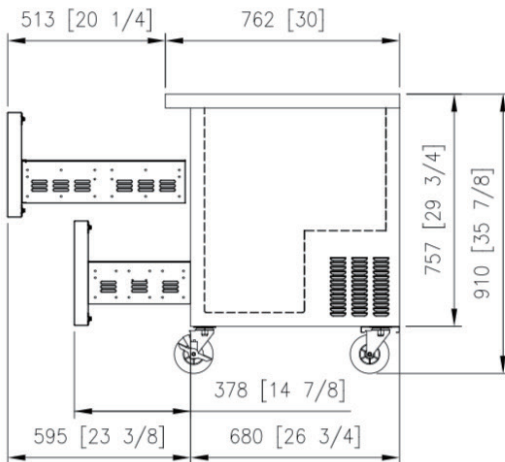

Spec

Electrical Data	
Voltage	115/60/1
Plug Type	 NEMA 5-15P
Full load Amperes	3.2
Compressor HP	1/5
Refrigerant	R-290

Dimensional Data	
Capacity (cu. ft.)	6.55
Net Weight (lbs.)	165

- **Warranty**
 - 4 year parts and labor warranty.
 - Additional 1 year warranty on compressor.
- **Slight Variations May Exist**

Grand[®]

Grand Manufacturing LLC
www.grandmfgllc.com

