



Grand Manufacturing LLC  
www.grandmfgllc.com

Project Name: \_\_\_\_\_

SIA #

Location: \_\_\_\_\_

Item #: \_\_\_\_\_ Qty: \_\_\_\_\_

AIA #

Model #: \_\_\_\_\_

Model:  
**GUR-48-D4**

## Grand Undercounter Series

48" 4 door undercounter refrigerator - Drawer



## Features & Benefits

### System

- Digital temperature control & monitor
- Hot gas condensate system
- Automatic evaporation & defrost system

### Strong & Durable Cabinet Finish

- Stainless steel finished top, front, sides and doors
- Galvanized steel finished back and bottom

### Components

- Accommodates 6" deep pans (pans are optional)
- 5" Heavy-duty casters with brakes standard

### Heavy Duty Drawer

- Stainless steel made telescoping drawer slide with roller bearing wheels
- Stainless steel made drawers hold up to 88 pounds (40kg)

### Temperature

- Enhanced Airflow Holds Product Temperature 32°F~41°F (0°C~5°C)

### Options

- Drawer Mixed Model Available
- Free Hcfc & Hfc Refrigerant Model (R-290)

Drawers	Shelves	HP	AMPS	Cabinet Dimensions (inches)			Crated Weight (lbs.)
				W	D	H*	
4	0	1/5	3.2	48 1/4	30	35 7/8	284

\* Exterior height include 5" for castor height.

GRAND has the right to change specifications without further notice.



Approvals:

Available At:

Model:  
**GUR-48-D4**

# Grand Undercounter Series

48" 4 door undercounter refrigerator - Drawer

## Plan View

### Top View

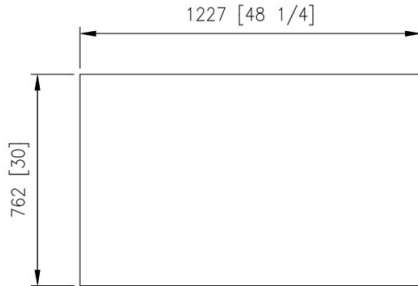

### Front View

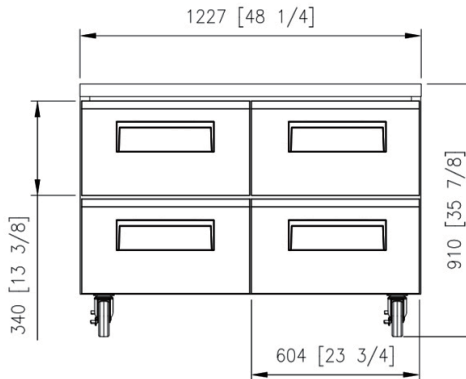

### Side View

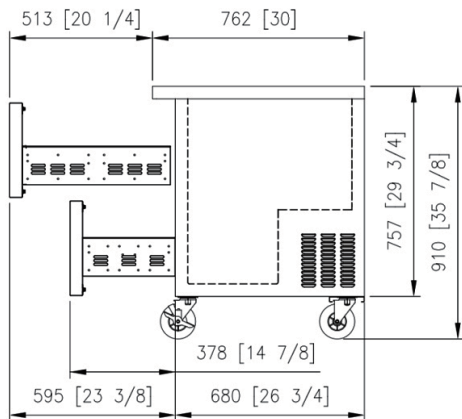

## Spec

Electrical Data	
Voltage	115/60/1
Plug Type	 NEMA 5-15P
Full load Amperes	3.2
Compressor HP	1/5
Refrigerant	R-290

Dimensional Data	
Capacity (cu. ft.)	12.23
Net Weight (lbs.)	267

- **Warranty**
  - 4 year parts and labor warranty.
  - Additional 1 year warranty on compressor.
- **Slight Variations May Exist**

**Grand**<sup>®</sup>

Grand Manufacturing LLC  
www.grandmfgllc.com

