



Grand Manufacturing LLC  
www.grandmfgllc.com

Project Name: \_\_\_\_\_

SIA #

Location: \_\_\_\_\_

Item #: \_\_\_\_\_ Qty: \_\_\_\_\_

AIA #

Model #: \_\_\_\_\_

Model:  
**GSU-36(10)-HC**

## Grand Food Prep Table Series

36" 2 door salad prep table



### Features & Benefits

#### Cabinet Construction

- Stainless steel interior and exterior; quality stainless steel helps to minimize dents, scratches, and rust.
- Entire cabinet structure and solid door are foamed-in-place using a high density, polyurethane insulation that has zero ozone depletion potential (ODP) and zero global warming potential (GWP).
- Drop-in section: cold air is circulated into this enclosed area keeping stored food fresh and consistently cold
- A stainless-steel partition prevents food spillage into the storage area beneath
- Accommodates 6" deep pans (4" pans are standard)
- Sturdy, epoxy coated wire shelves with adjustable shelving height
- Insulated top lid

#### Refrigeration

- Hydrocarbon refrigerants (R-290): Innovative eco-friendly technology, R290 hydrocarbon refrigerant has zero (0) ozone depletion potential (ODP), & three (3) global warming potential (GWP).
- Anti-corrosion epoxy coated evaporator helps eliminate the potential corrosion.
- Automatic defrost and fabric condensate evaporation system
- Refrigerator holds 32°F ~ 39°F for the best in food preservation

#### Doors

- Self-closing doors
- Durable door gasket with easy replacement
- Heavy-duty insulation

#### Standard

- NSF/ANSI Standard 7

Doors	Shelves	Pans	HP	AMPS	Cabinet Dimensions (inches)			Crated Weight (lbs.)
					W	D	H	
2	2	10	1/5	3.4	36 3/8	30	42 1/2	203

\* Exterior height include 5" for castor height.

GRAND has the right to change specifications without further notice.



Approvals:

Available At:

Model:  
**GSU-36-10-HC**

# Grand Food Prep Table Series

36" 2 door salad prep table

## Plan View

### Side View

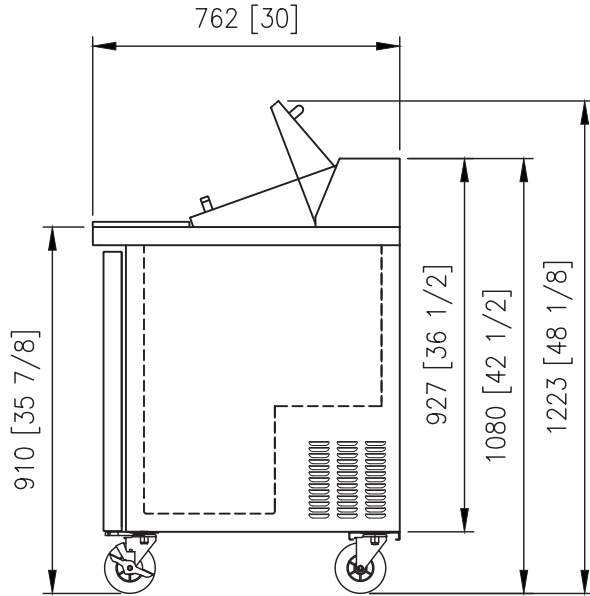

### Top View

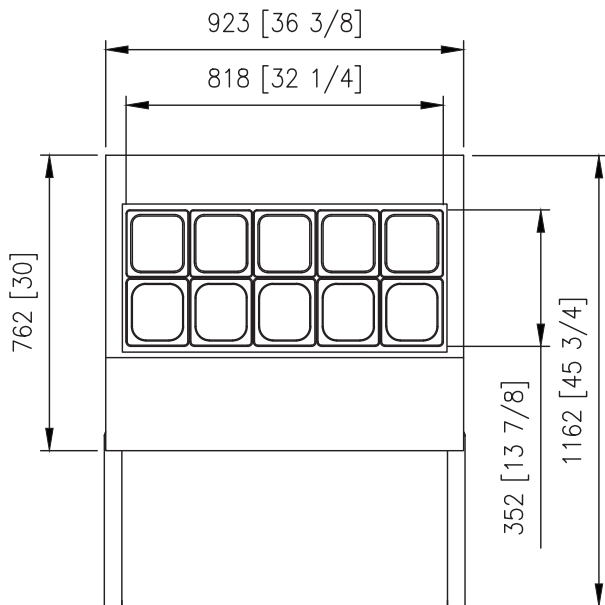

## Spec

Electrical Data	
Voltage	115/60/1
Plug Type	 NEMA 5-15P
Full load Amperes	3.4
Compressor HP	1/5
Refrigerant	R-290

Dimensional Data	
Capacity (cu. ft.)	8.92
Net Weight (lbs.)	190
Shelf Size (L x D) (inch)	15.43 x 19.21

### ■ Warranty

- 4 year parts and labor warranty.
- Additional 1 year warranty on compressor.

### ■ Optional Accessories

- Additional PE coated wire shelf

### ■ Slight Variations May Exist

**Grand**<sup>®</sup>

Grand Manufacturing LLC  
www.grandmfgllc.com

