



Grand Manufacturing LLC
www.grandmfgllc.net

Project Name: _____

SIA #

Location: _____

Item #: _____ Qty: _____

AIA #

Model #: _____

Model:
GMU-72(30)-HC

Grand Food Prep Table Series

72" 3 door megatop table



Features & Benefits

Cabinet Construction

- Stainless steel interior and exterior; quality stainless steel helps to minimize dents, scratches, and rust.
- Entire cabinet structure and solid door are foamed-in-place using a high density, polyurethane insulation that has zero ozone depletion potential (ODP) and zero global warming potential (GWP).
- Drop-in section: cold air is circulated into this enclosed area keeping stored food fresh and consistently cold
- A stainless-steel partition prevents food spillage into the storage area beneath
- Accommodates 6" deep pans (4" pans are standard)
- Sturdy, epoxy coated wire shelves with adjustable shelving height
- Insulated top lid

Refrigeration

- Hydrocarbon refrigerants (R-290): Innovative eco-friendly technology, R290 hydrocarbon refrigerant has zero (0) ozone depletion potential (ODP), & three (3) global warming potential (GWP).
- Anti-corrosion epoxy coated evaporator helps eliminate the potential corrosion.
- Automatic defrost and fabric condensate evaporation system
- Refrigerator holds 32°F ~ 39°F for the best in food preservation

Doors

- Self-closing doors
- Durable door gasket with easy replacement
- Heavy-duty insulation

Standard

- NSF/ANSI Standard 7

Doors	Shelves	Pans	HP	AMPS	Cabinet Dimensions (inches)			Crated Weight (lbs.)
					W	D	H	
3	3	30	3/8	6.1	72 3/8	35 1/4	44 1/8	353

* Exterior height include 5" for castor height.

GRAND has the right to change specifications without further notice.



Approvals:

Available At:

Model:
GMU-72(30)-HC

Grand Food Prep Table Series

72" 3 door megatop table

Plan View

Side View

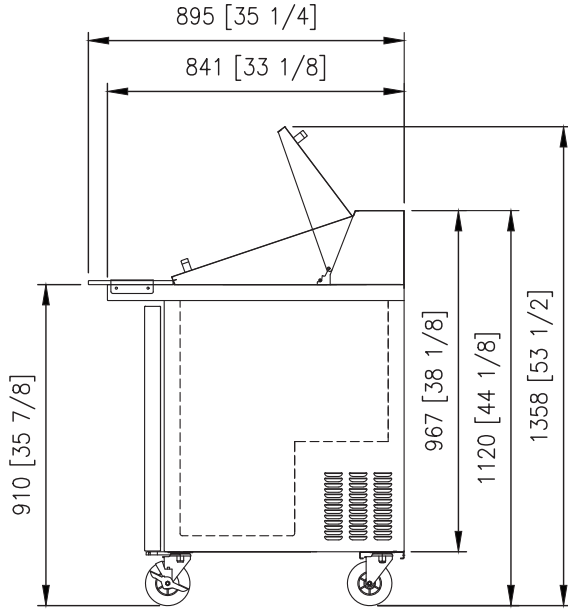

Top View

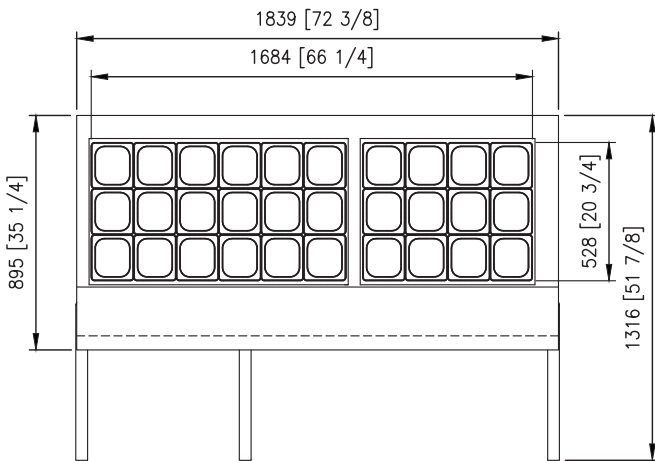

Spec

Electrical Data	
Voltage	115/60/1
Plug Type	NEMA 5-15P
Full load Amperes	6.1
Compressor HP	3/8
Refrigerant	R-290

Dimensional Data	
Capacity (cu. ft.)	18.75
Net Weight (lbs.)	324
Shelf Size (L x D) (in.)	21.46 × 19.21 (Left/Right)
	22.52 × 19.21 (Middle)

■ Warranty

- 4 year parts and labor warranty.
- Additional 1 year warranty on compressor.

■ Optional Accessories

- Additional PE coated wire shelf (sides)
- Additional PE coated wire shelf (middle)

■ Slight Variations May Exist

Grand[®]

Grand Manufacturing LLC
www.grandmfgllc.net

