



Grand Manufacturing LLC
www.grandmfgllc.net

Project Name: _____

SIA #

Location: _____

Item #: _____ Qty: _____

AIA #

Model #: _____

Model:
GMU-60(24)-D4

Grand Food Prep Table Series

60" 4 door megatop table - Drawer



Features & Benefits

System

- Digital temperature control & monitor
- Hot gas condensate system
- Automatic evaporation & defrost system
- 70-degree-open and insulated stainless steel covers eliminate heat transfer and protect products when closed
- Locking the dispenser bar locks the pan in place to prevent product spills

Strong & Durable Cabinet Finish

- Stainless steel finished top, front, sides and doors
- Galvanized steel finished back and bottom

Components

- Accommodate 6" deep pans (pans are optional)
- Compact size (344mm) and reversible cutting board is easily removed for cleaning or additional use
- PVC coated sturdy wire shelves
- 4" heavy duty casters with brakes standard

User Friendly Door

- Auto-closing doors
- Sturdy and easy-grip handles and doors that open effortlessly
- Magnetic door gasket provides an easy-to-remove feature for cleaning or replacement feature

Temperature

- Enhanced Airflow Holds Product Temperature 32°F~41°F (0°C~5°C)

Options

- Drawer mixed model available
- Leg models available

Drawers	Pans	HP	AMPS	Cabinet Dimensions (inches)			Crated Weight (lbs.)
				W	D	H	
4	24	3/8	6.0	60 3/8	35 1/4	44 1/8	366

* Exterior height include 5" for castor height.

GRAND has the right to change specifications without further notice.



Approvals:

Available At:

Model:
GMU-60(24)-D4

Grand Food Prep Table Series

48" 4 door megatop table - Drawer

Plan View

Top View

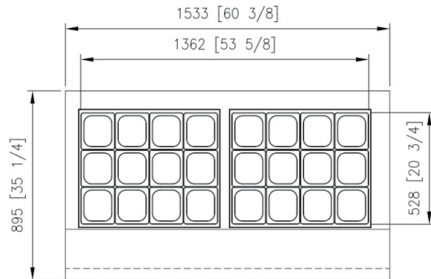

Front View

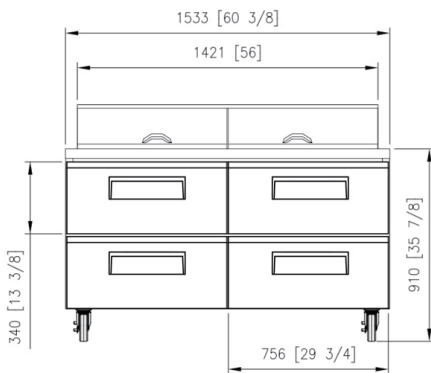

Side View

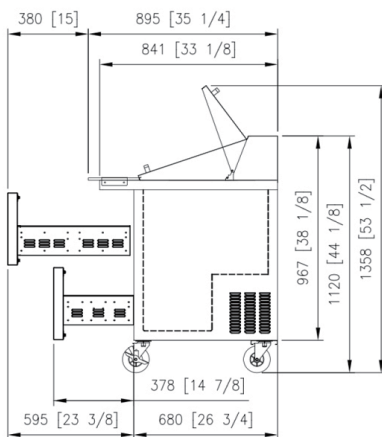

Spec

Electrical Data	
Voltage	115/60/1
Plug Type	 NEMA 5-15P
Full load Amperes	6.0
Compressor HP	3/8
Refrigerant	R-290

Dimensional Data	
Capacity (cu. ft.)	15.56
Net Weight (lbs.)	344

■ Warranty

- 4 year parts and labor warranty.
- Additional 1 year warranty on compressor.

■ Optional Accessories

- Additional PE coated wire shelf

■ Slight Variations May Exist

Grand[®]

Grand Manufacturing LLC
www.grandmfgllc.net

