



Grand Manufacturing LLC
www.grandmfgllc.com

Project Name: _____

SIA #

Location: _____

Item #: _____ Qty: _____

AIA #

Model #: _____

Model:
GCB-48-HC

Grand Chef Base Series

48" 2 Drawers Chef Base



Features & Benefits

Cabinet Construction

- Stainless steel interior and exterior; quality stainless steel helps to minimize dents, scratches, and rust.
- Entire cabinet structure and solid door are foamed-in-place using a high density, polyurethane insulation that has zero ozone depletion potential (ODP) and zero global warming potential (GWP).
- Drop-in section: cold air is circulated into this enclosed area keeping stored food fresh and consistently cold
- A stainless-steel partition prevents food spillage into the storage area beneath
- Accommodates 6" deep pans (4" pans are standard)
- Sturdy, epoxy coated wire shelves with adjustable shelving height
- Insulated top lid
- Top Stainless-steel frame of top food zone and for pan partition

Refrigeration

- Hydrocarbon refrigerants (R-290): Innovative eco-friendly technology, R290 hydrocarbon refrigerant has zero (0) ozone depletion potential (ODP), & three (3) global warming potential (GWP).
- Anti-corrosion epoxy coated evaporator helps eliminate the potential corrosion.
- Automatic defrost and fabric condensate evaporation system
- Refrigerator holds 32°F ~ 39°F for the best in food preservation

Doors

- Self-closing doors
- Durable door gasket with easy replacement
- Heavy-duty insulation

Standard

- NSF/ANSI Standard 7

Drawers	HP	AMPS	Top Weight Capacity (lbs.)	Cabinet Dimensions (inches)			Crated Weight (lbs.)
				W	D	H	
2	1/5	3.3	558	48	30 1/2	25 1/2	220

* External dimensions include 4"caster height - marine edge standard ** Pans not included

*** GRAND has the right to change specifications without further notice.



Approvals:

Available At:

Model:
GCB-48-HC

Grand Chef Base Series

48" 2 Drawers Chef Base

Plan View

Top View

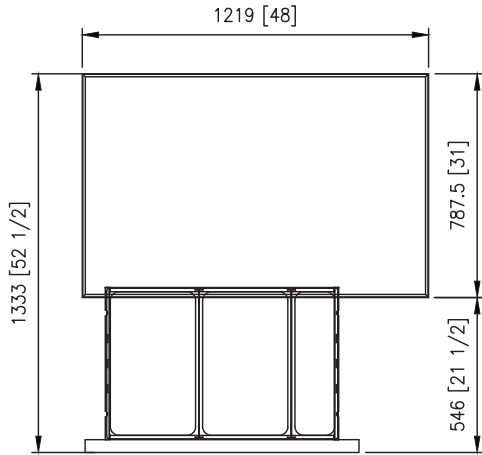

Front View

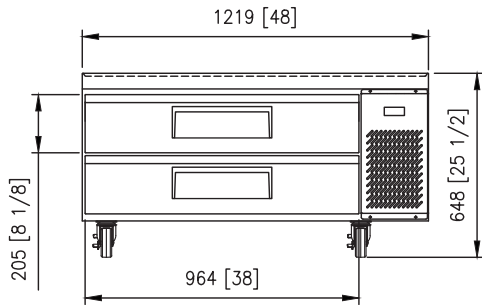

Side View

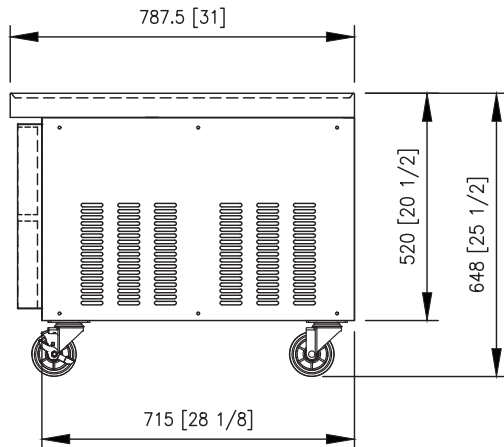

Spec

Electrical Data	
Voltage	115/60/1
Plug Type	 NEMA 5-15P
Full load Amperes	3.3
Compressor HP	1/5
Refrigerant	R-290

Dimensional Data	
Capacity (cu. ft.)	8.6
Net Weight (lbs.)	207

■ Warranty

- 3 year parts and labor warranty.
- Additional 2 year warranty on compressor.

■ Slight Variations May Exist

Grand[®]

Grand Manufacturing LLC
www.grandmfgllc.com

